

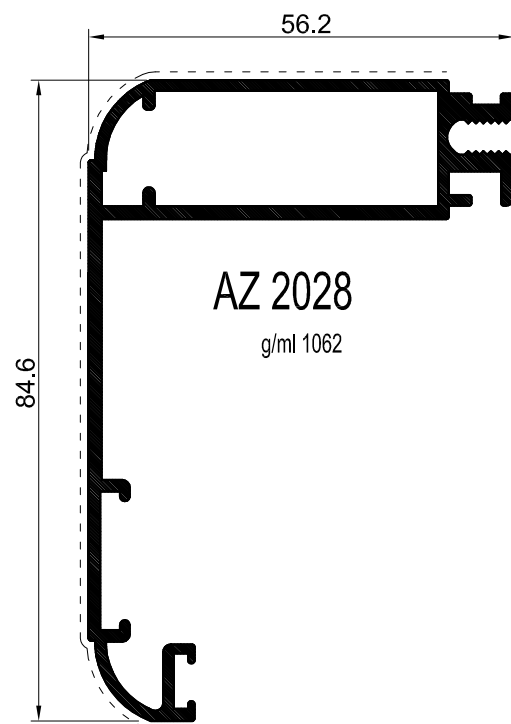

Atlantis
Porte Interne

Atlantis

Porte Interne

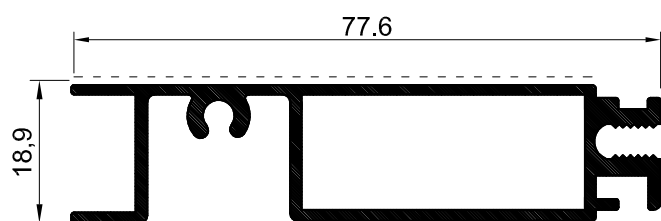
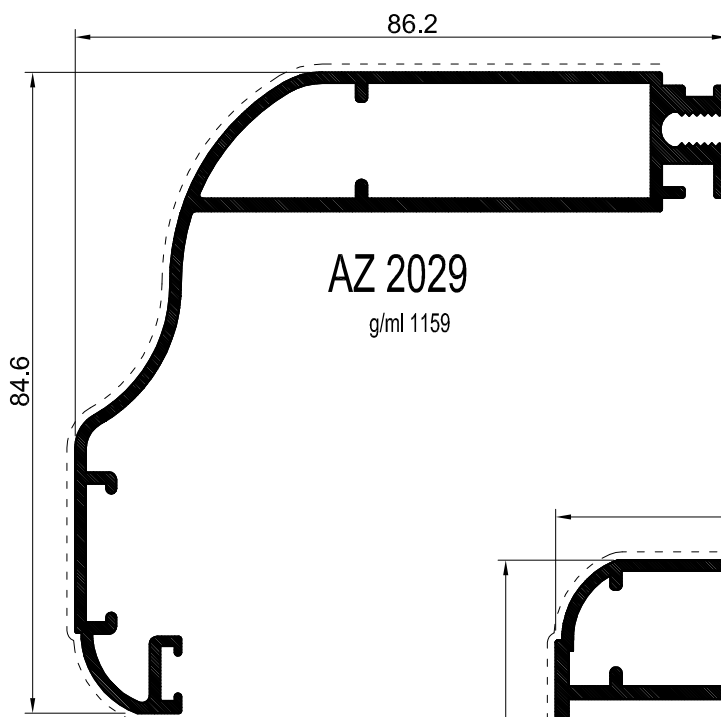
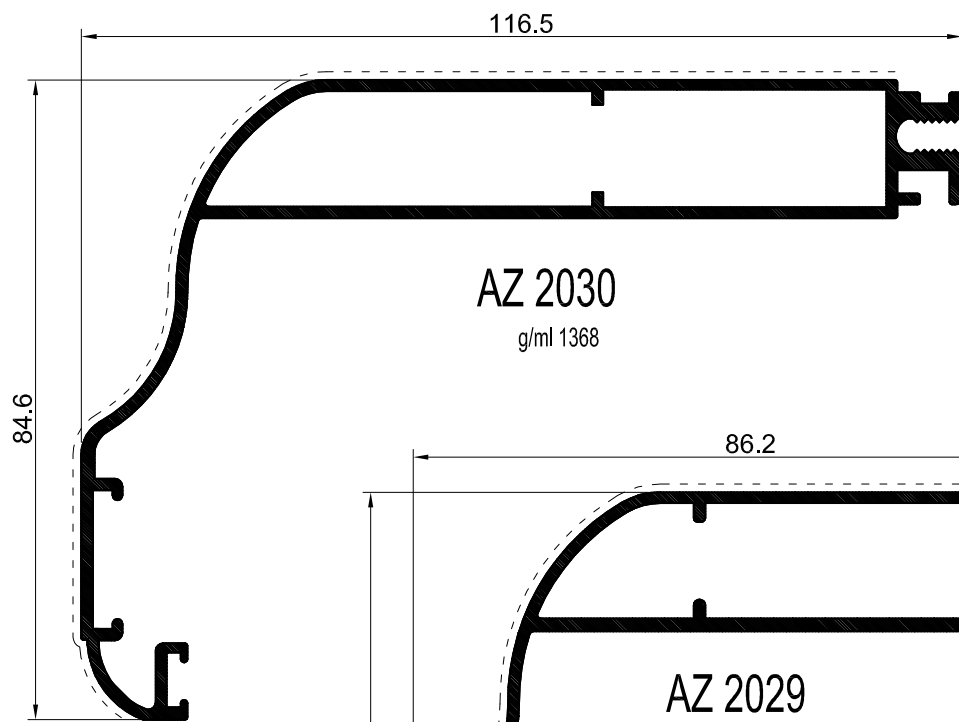

Atlantis

Porte Interne

AZ2073

GR/ML 263

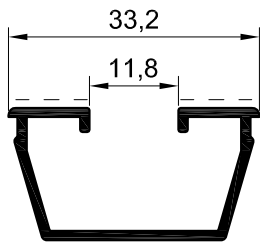

102.9

AZ2026

GR/ML 1533

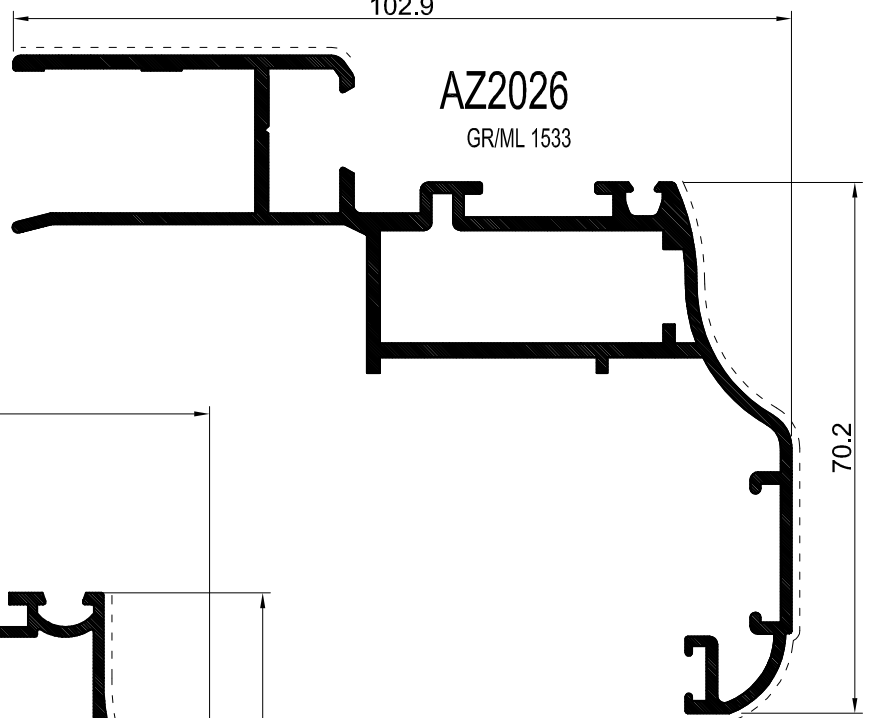

86

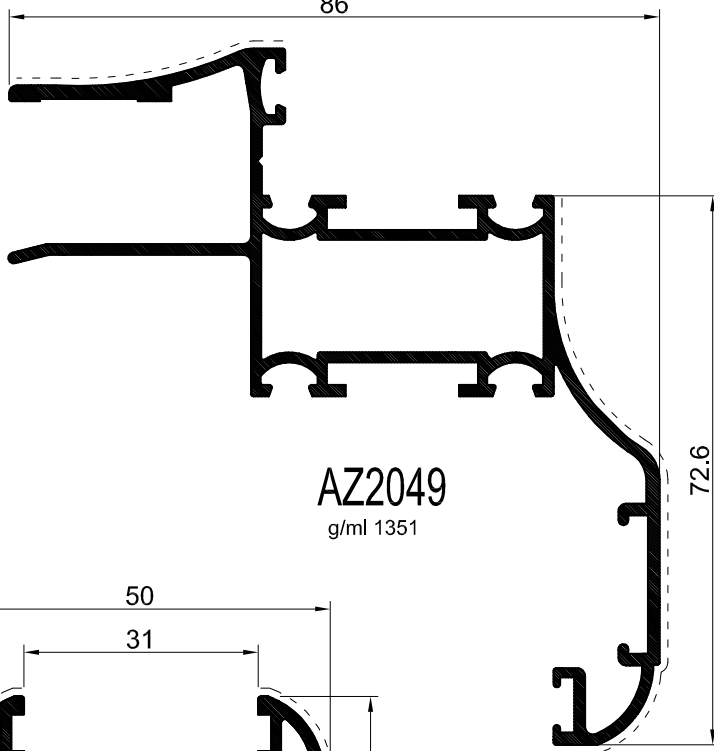

AZ2049

g/ml 1351

50

31

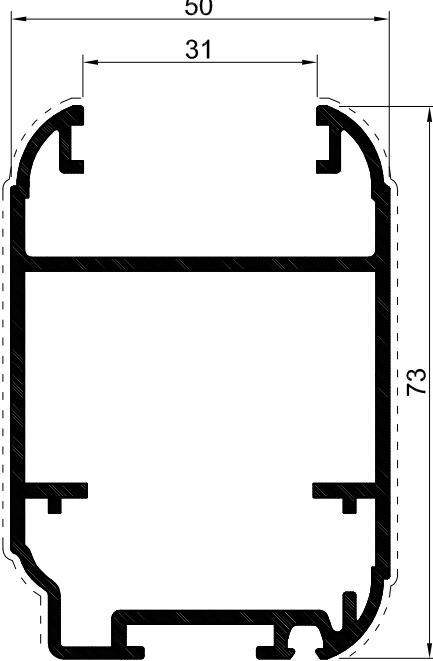

AZ 2027

GR/ML 1290

51.8

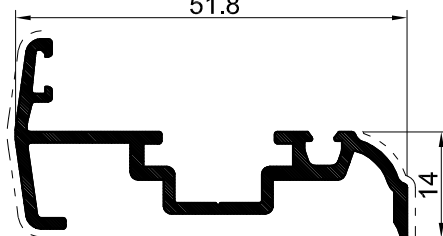

AZ 2032

GR/ML 477

34.3

30.5

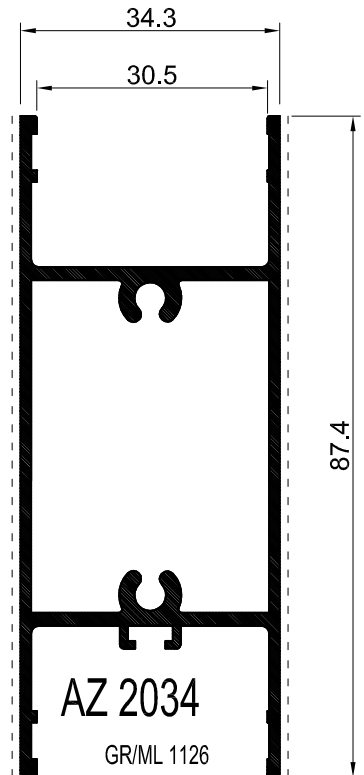

AZ 2034

GR/ML 1126

Atlantis

Porte
Interne

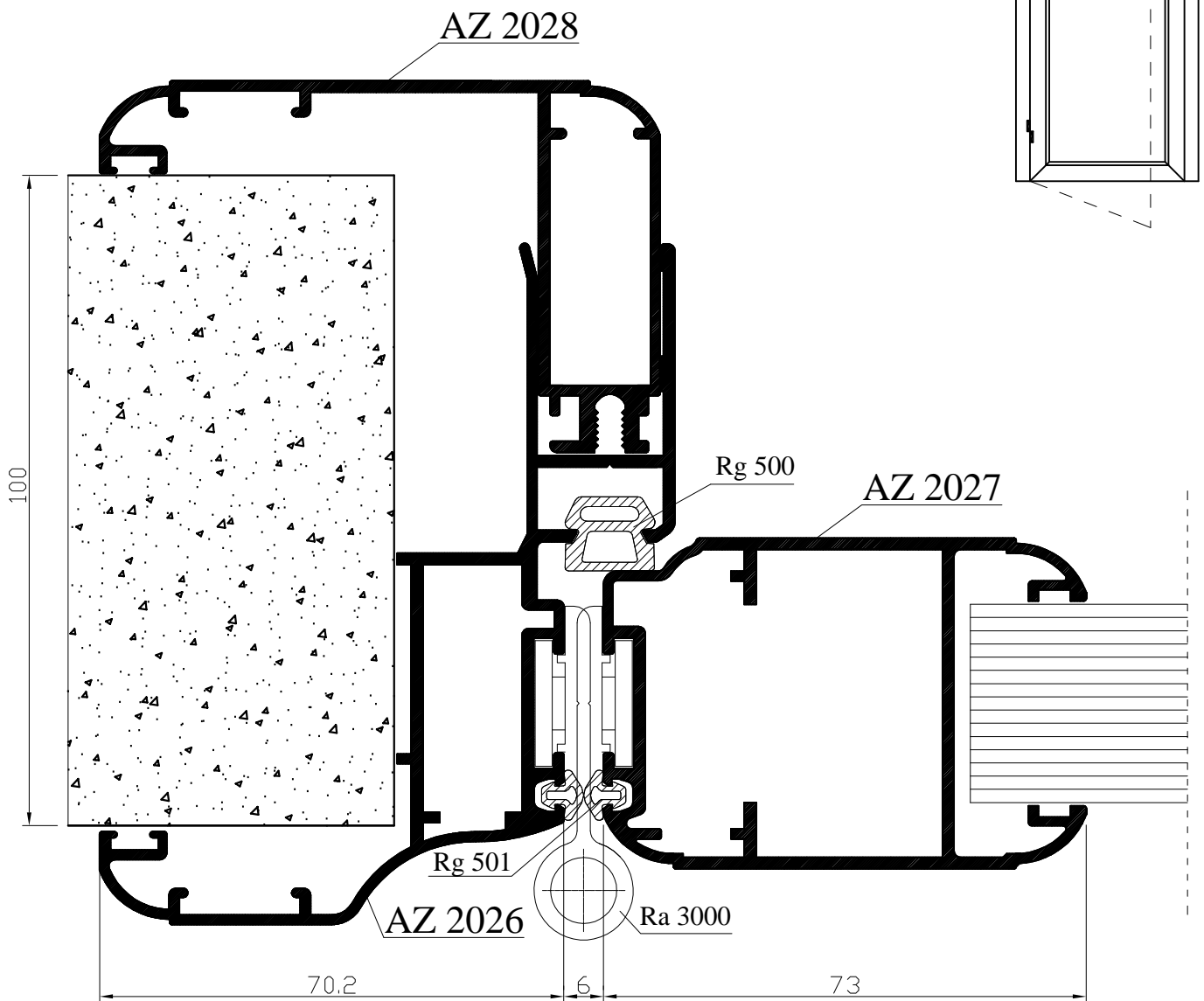
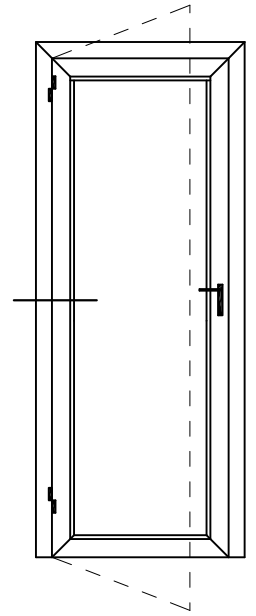

Atlantis

Porte
Interne

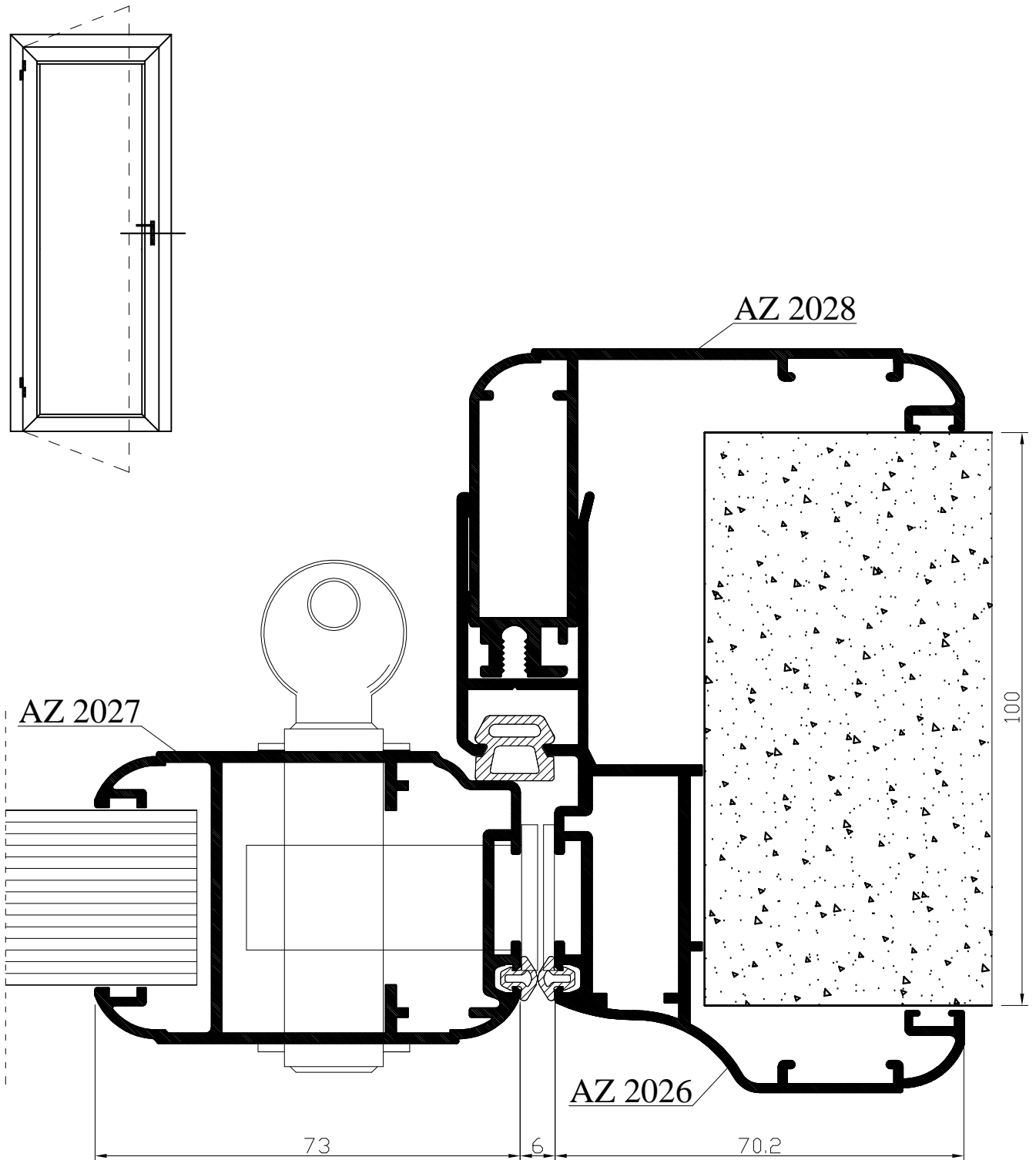

Atlantis

Porte
Interne

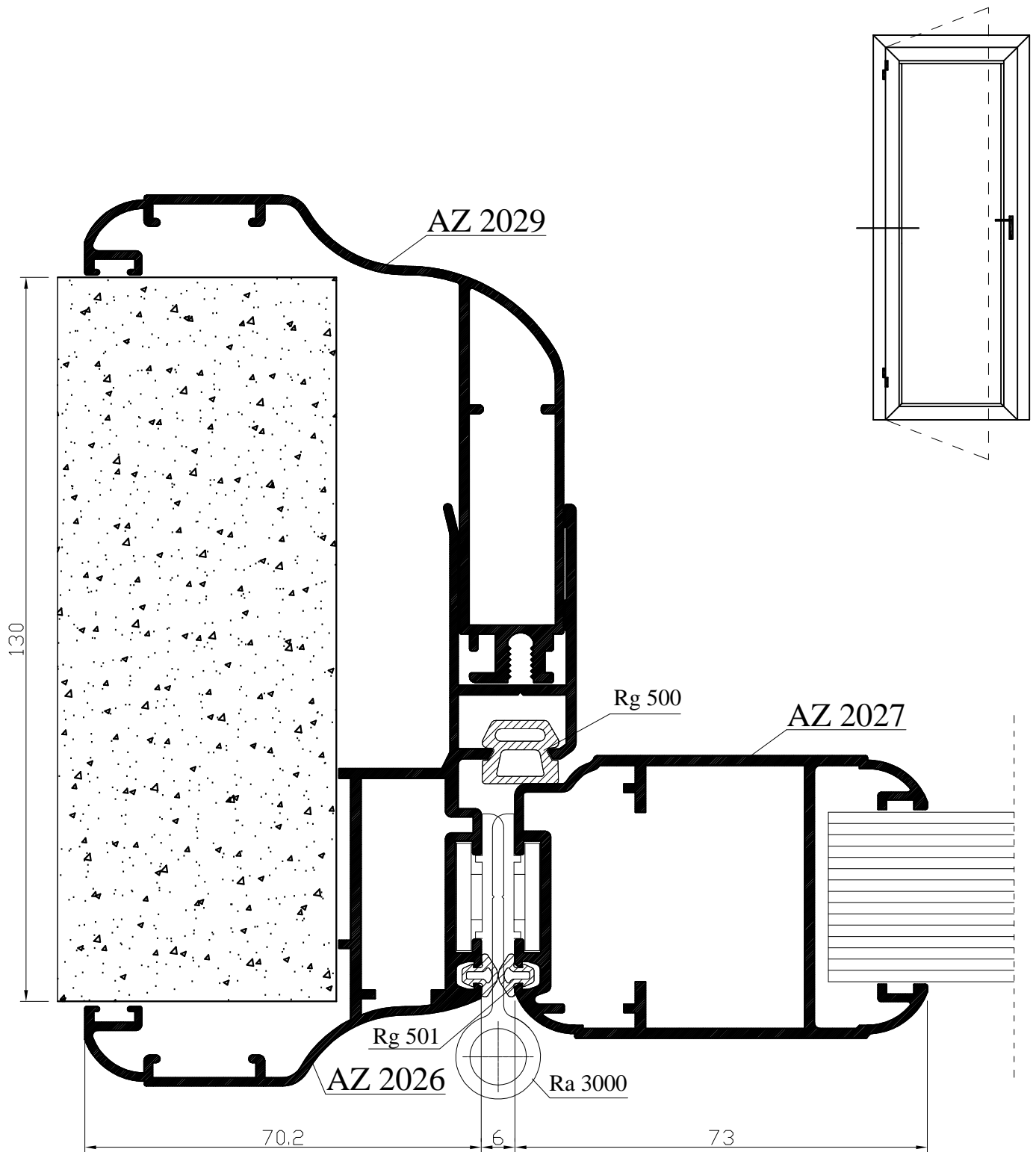

Atlantis

Porte
Interne

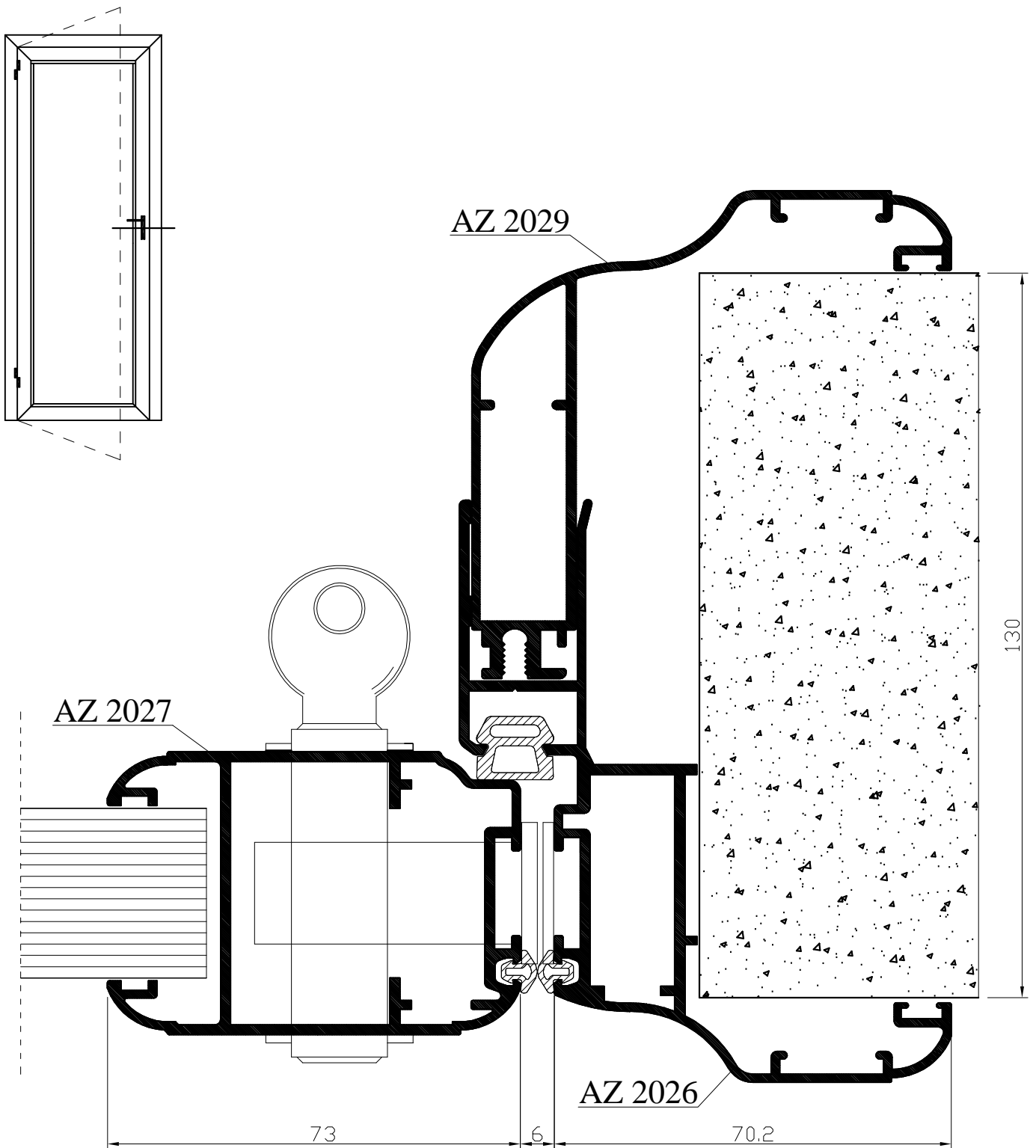

Atlantis

Porte
Interne

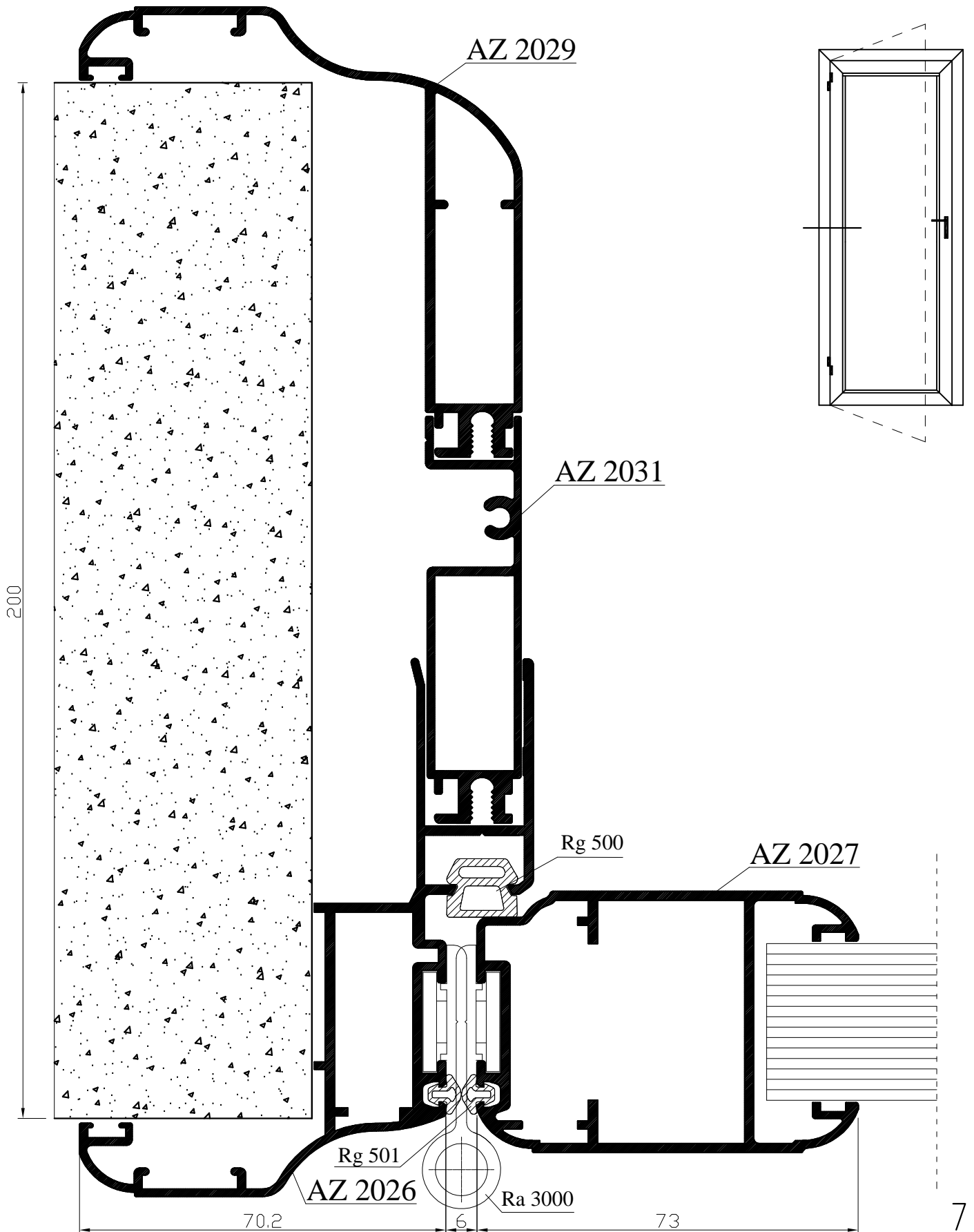

Atlantis

Porte
Interne

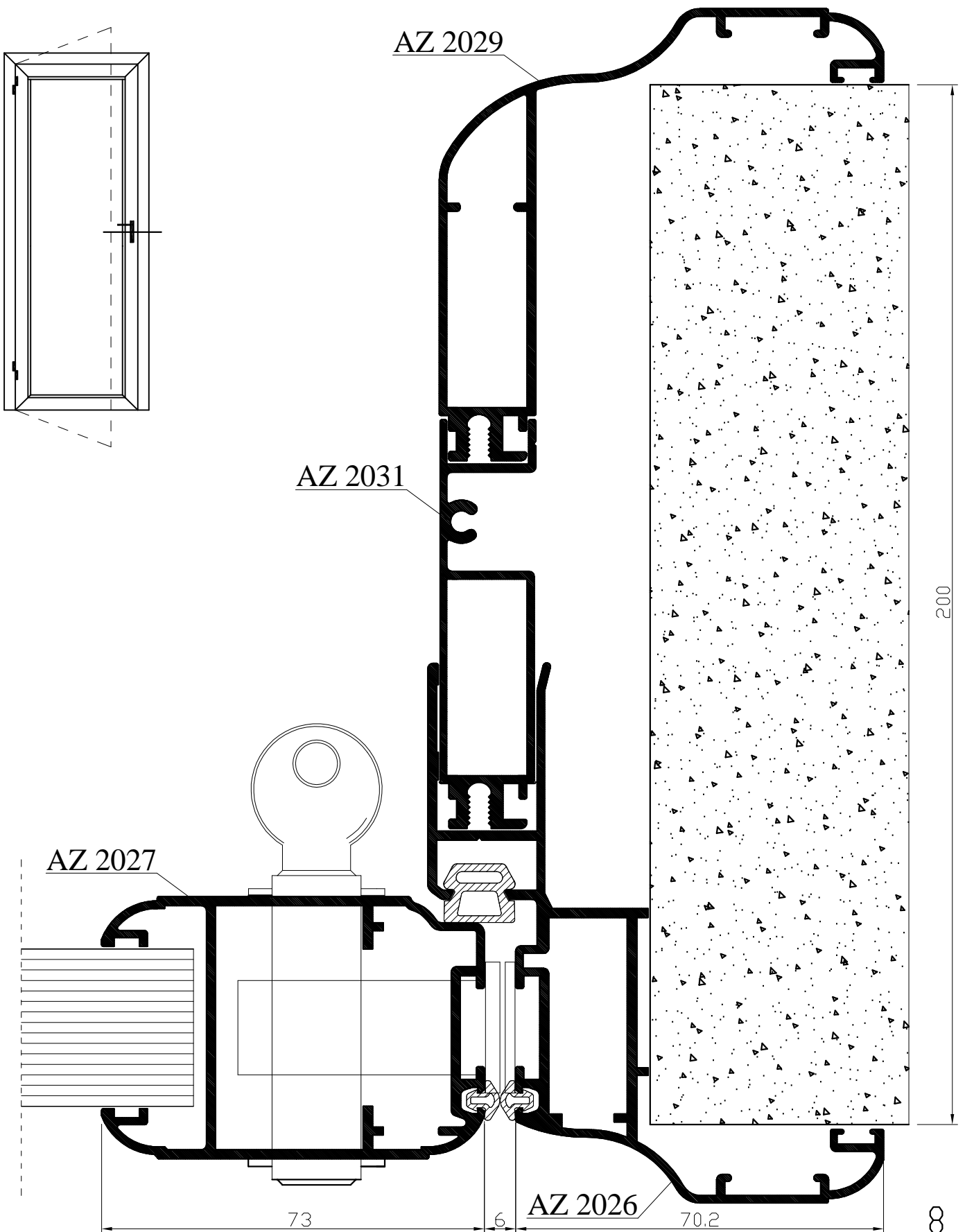

Atlantis

Porte Interne

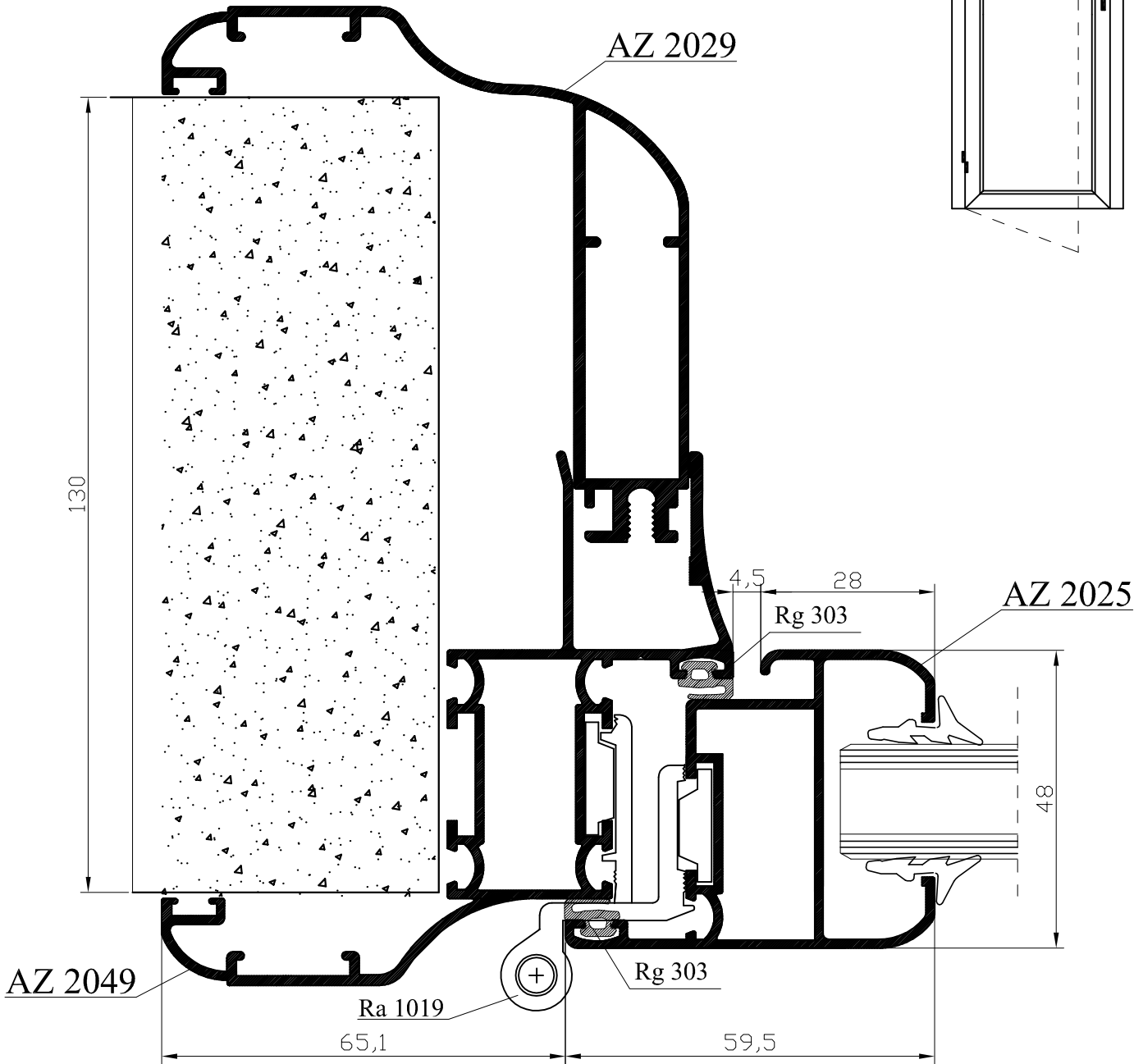
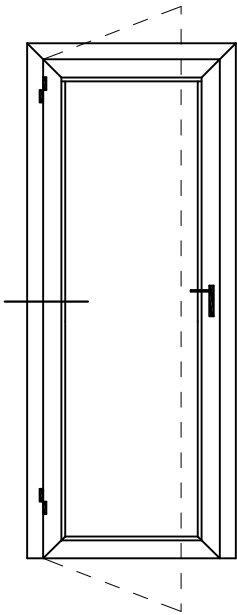

Atlantis
Porte Interne

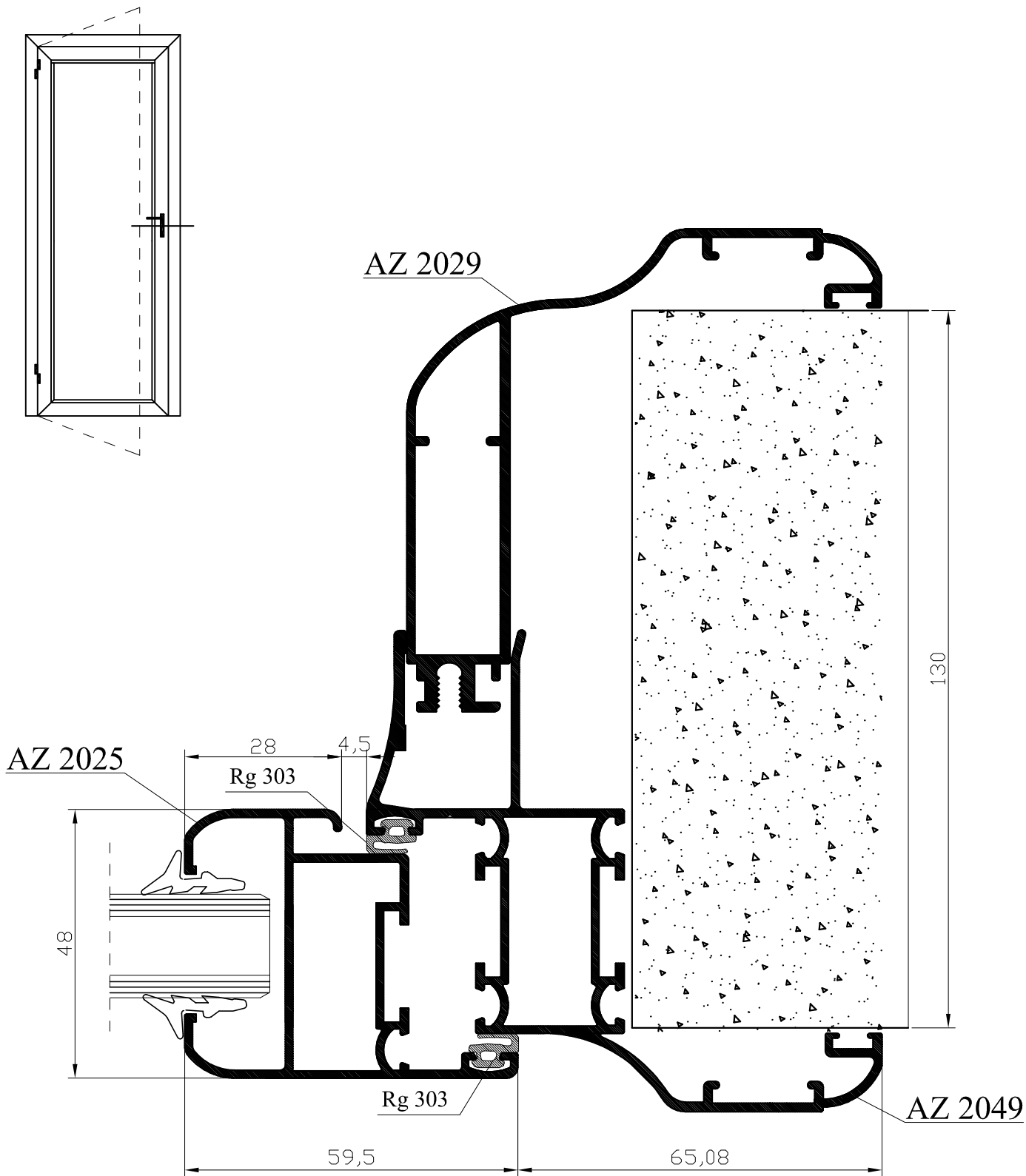

Atlantis

Porte
Interne

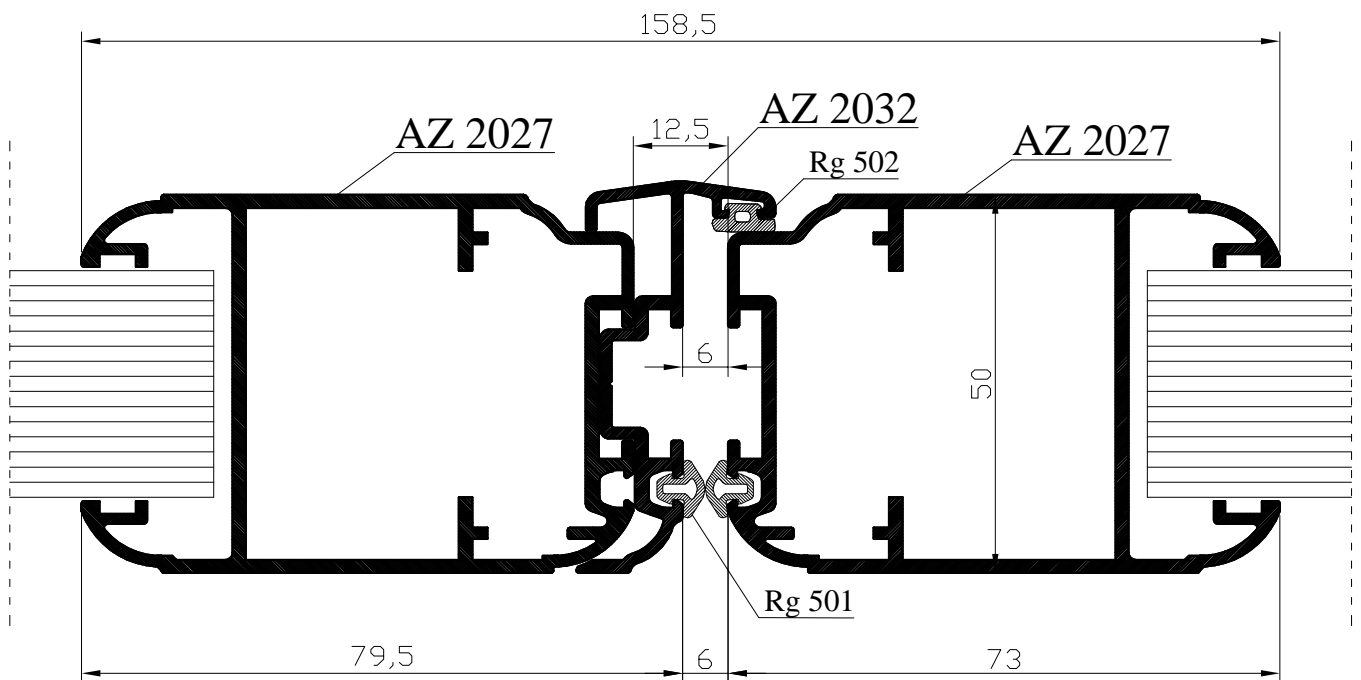
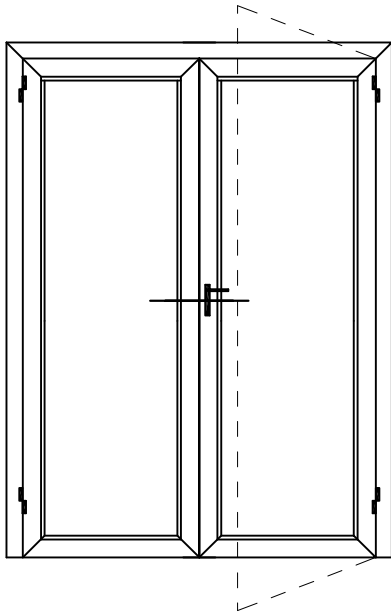

Atlantis

Porte
Interne

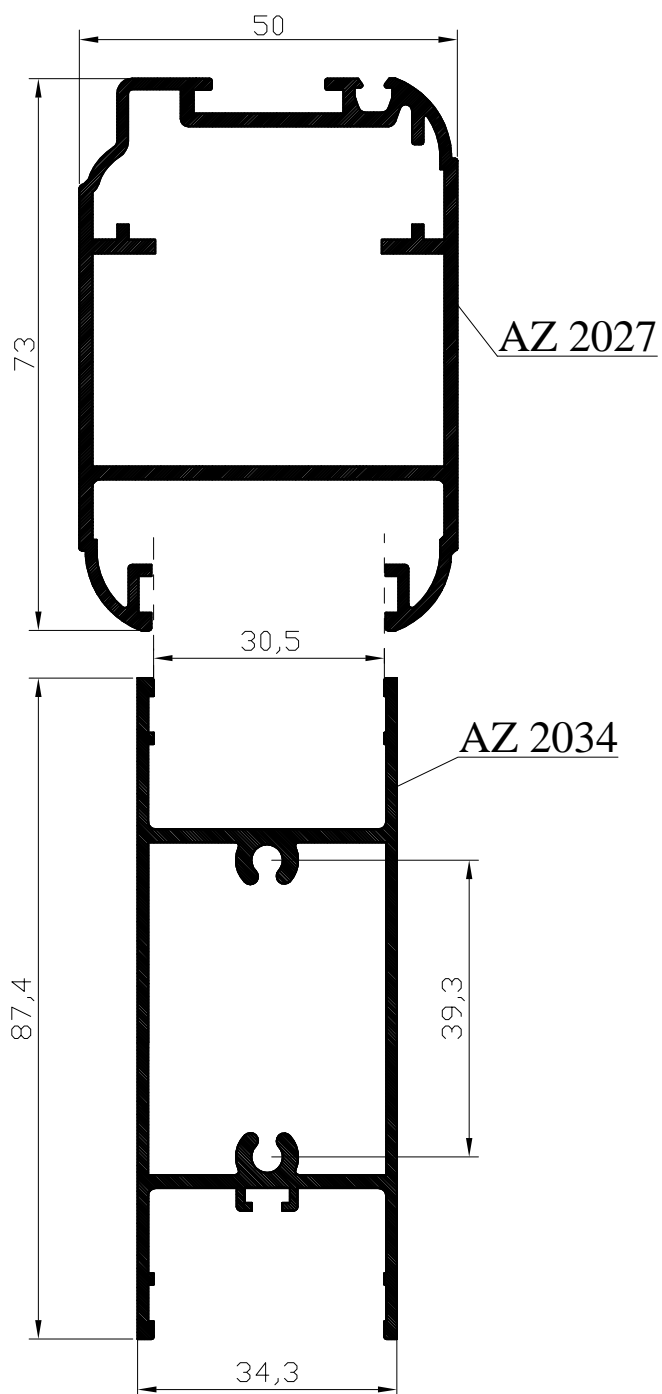
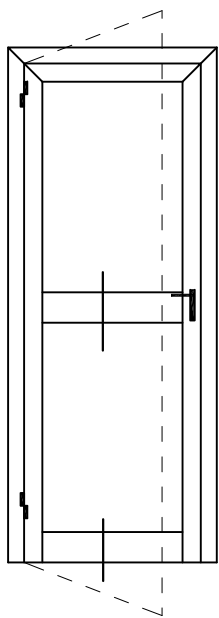

distinte di taglio cutting size

PORTA INTERNA A 1 ANTA

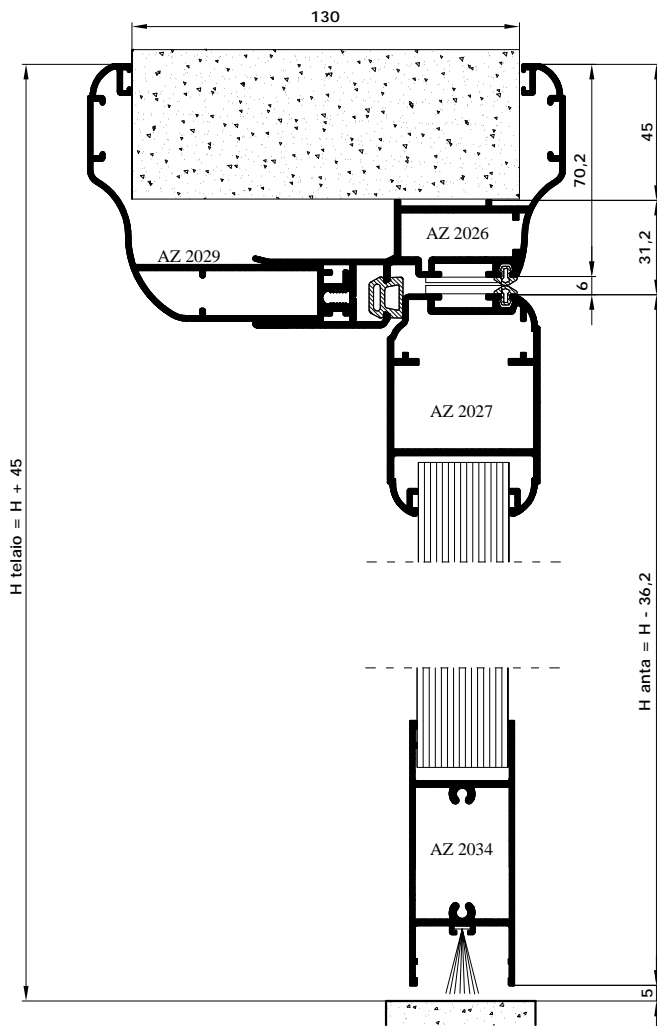
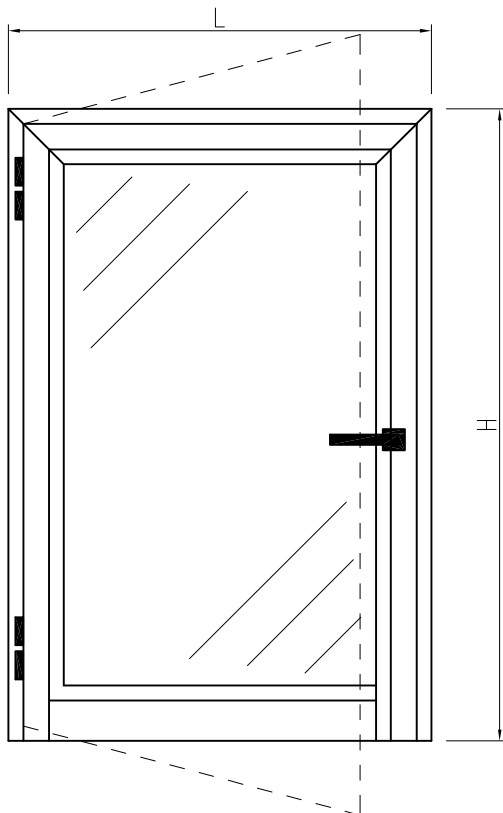

CALCOLO PESO PROFILI		TOTALE KG
Profili Orizz.	Kg/ml $7,5 \times L$	
Profili Vert.	Kg/ml $7,5 \times H$	
TOTALE		

DISTINTA TAGLIO VETRI			
Posizione	l	h	Q.tà
	L - 170	H - 95	1

L telaio = L + 90

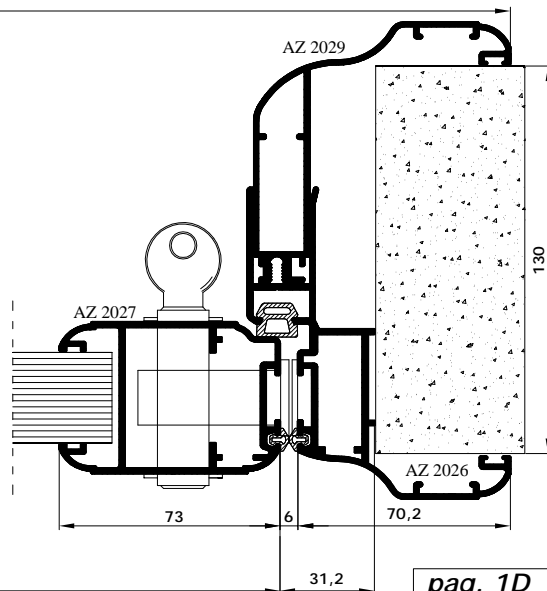
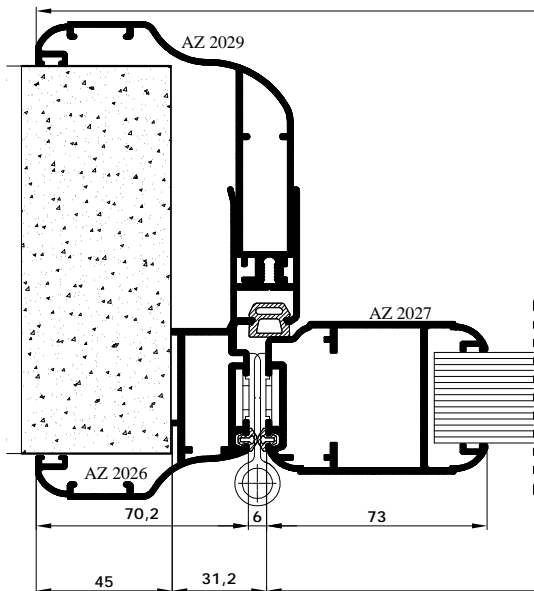

L anta = L - 62,4

PORTA INTERNA A 1 ANTA

DISTINTA TAGLIO PROFILI			
Nr. Pezzi	CODICI	DESCRIZIONE	TAGLIO
2	AZ 2026	MONTANTE TELAIO	 H+45
2	AZ 2029	MONTANTE TELAIO	 H+45
1	AZ 2026	TRAVERSO SUP. TELAIO	 L+90
1	AZ 2029	TRAVERSO SUP. TELAIO	 L+90
1	AZ 2027	TRAVERSO ANTA	 L-62,4
2	AZ 2027	MONTANTE ANTA	 H-36,2
1	AZ 2034	ZOCCOLO	 H-168,2

GUARNIZIONI			
	ART.	DESCRIZIONE	N° P.zzi
	Rg 500	G. DI BATTUTA	L + 2H
	4,8 x 6	SPAZZOLINO DA 6 mm	L + 2H
	40 x 20	SPAZZOLINO DA 20 mm	L

ACCESSORI		
ART.	DESCRIZIONE	N° P.zzi
Ra 1014	SERRATURA E CONTROPIASTRA	1
Ra 1048	SQUADRETTA	6
Ra 3000	CERNIERA	3
Ra 3001	MANIGLIA	1
Ra 3002	SQUADRETTA DI ALLINEAMENTO TELAI	4